

Overview

SIGI-271 Fire Alarm Call Points are part of GE's Signature Series system. These integrated assemblies feature the familiar KAC Installers' Series Call Point packaged with Signature Series intelligent addressable/analogue interface electronics.

In all 271 Series Call Points, the switch is held off by the edge of the glass. When the glass is broken by pressing directly on it, the switch is released and an alarm sent to the Signature loop controller. A protective plastic coating on the glass prevents operator injury and inhibits the release of glass fragments.

Each Signature Series Call Point constantly runs self-checks to provide important maintenance information. The results of the self-check are automatically updated and permanently stored in the Call Point's non-volatile memory. This information is accessible for review any time at the control panel, PC, or by using the SIGA-PRO Signature Program/Service Tool.

The information stored in the Call Point's memory includes:

- Call Point serial number, address, type code.
- Manufacture date, hours of operation, last maintenance date.
- Number of recorded troubles, alarms, time and date of last alarm.
- Up to 24 possible trouble codes that may be used to specifically diagnose faults.

The Signature loop controller learns where each device's serial number address is installed relative to other Signature devices on the circuit. The loop controller keeps a "map" of the Signature Series devices connected to it.

Standard Features

- **Intelligent Device with Integral Microprocessor**
All decisions are made at the Call Point to allow lower communication speed. Lower communication speeds are less sensitive to line noise; twisted or shielded wire is not required.
- **Automatic Device Mapping**
Each Call Point transmits wiring information regarding its location with respect to other Signature devices on the circuit.
- **Electronic Addressing**
Addresses are downloaded from a PC, or the SIGA-PRO Signature Program/Service Tool. There are no switches or dials to set.
- **Non-volatile Memory**
Permanently stores serial number, type of device, and job number. Automatically updated with historic information.
- **Stand-alone Operation**
Call Point can input an alarm even if the loop controller's polling interrogation stops.
- **Alarm LED**
Red led flashes to show "alarm" state.
- **Designed For High Ambient Temperature Operation**
Install in ambient temperatures up to 120 °F (49 °C).
- **Flush or Surface Mount**
- **Optional Markings Available**
Glass inserts with multiple languages are available.
- **Designed To ISO 9001 Standard**
Manufactured to strict international quality standards.

Intelligent Break Glass Call Point

SIGI-271



Application

The operating characteristics of the fire alarm Call Point is determined by its sub-type code or "Personality Code". NORMALLY OPEN ALARM - LATCHING (Personality Code 1) is assigned by the factory; no user configuration is required. The device is configured for Class B IDC operation. An ALARM signal is sent to the loop controller when the switch is closed (i.e. when the glass is broken). The alarm condition is latched at the station.

Compatibility

Signature Series Call Points are compatible only with Signature Loop Controller.

Testing & Maintenance

To test the Call Point simply insert the special test key (provided with every unit); the glass drops and the switch closes. Removing the key restores the Call Point to normal.

The Call Point's automatic self-diagnosis identifies when it is defective and causes a trouble message. The user-friendly maintenance program shows the current state of each Signature Series device and other pertinent messages. Single devices may be deactivated temporarily, from the control panel. Availability of some maintenance features is dependent on the fire alarm system used.

Scheduled maintenance (Regular or Selected) for proper system operation should be planned to meet the requirements of the Authority Having Jurisdiction (AHJ).

Testing & Maintenance

To test the Call Point simply insert the special test key (provided with every unit); the glass drops and the switch closes. Removing the key restores the Call Point to normal.

The Call Point's automatic self-diagnosis identifies when it is defective and causes a trouble message.

The user-friendly maintenance program shows the current state of each Signature Series device and other pertinent messages. Single devices may be deactivated temporarily, from the control panel. Availability of some maintenance features is dependent on the fire alarm system used.

Scheduled maintenance (Regular or Selected) for proper system operation should be planned to meet the requirements of the Authority Having Jurisdiction (AHJ).

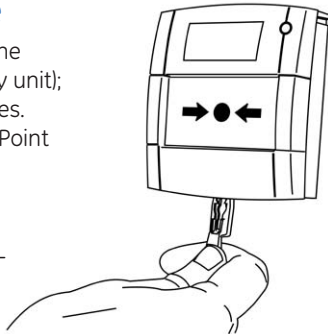

Installation and Mounting

The Signature Series fire alarm Call Points flush mount to standard European General Purpose Outlet Boxes using the KAC ETT/1-P European Terminal Tray. Surface mounting requires the KAC SR3T-P Surface Mounting Box. GE Security recommends that Call Points be installed according to latest recognized edition of national and local fire alarm codes.

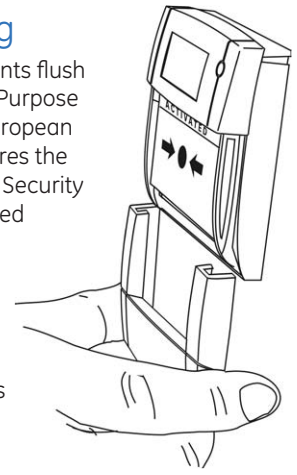

Electronic Addressing - The Signature loop controller electronically addresses each Call Point, saving valuable time during system commissioning. Setting complicated switches or dials is not required. Each Call Point has its own unique serial number stored in its "on-board memory". The loop controller identifies each device on the loop and assigns a "soft" address to each serial number. If desired, the Call Points can be addressed using the SIGA-PRO Signature Program/Service Tool.

Warnings & Cautions

This device will not operate without electrical power. As fires frequently cause power interruption, we suggest you discuss further safeguards with your fire protection specialist.

Dimensions

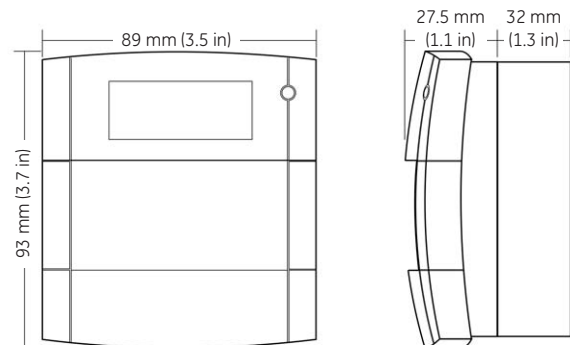

Typical Wiring

Connecting to the Call Point is made easy, and virtually 'Plug-in'. The Call Point is supplied with flying leads and grip forks that connect to large terminals in the ETT/1 or SR3T mounting accessory. Installer cables are accommodated in robust 'clamp type' terminals that will each take two conductors in the manner required by BS5839: Part 2. See Signature Loop Controller catalogue sheet for detailed wiring requirement specifications.

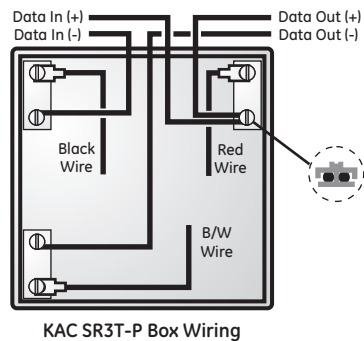
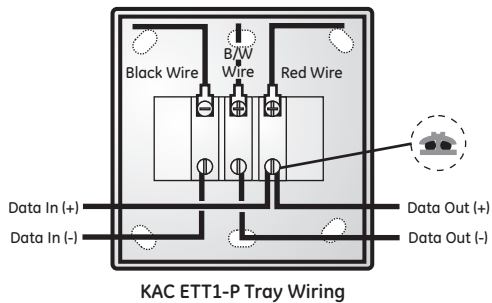
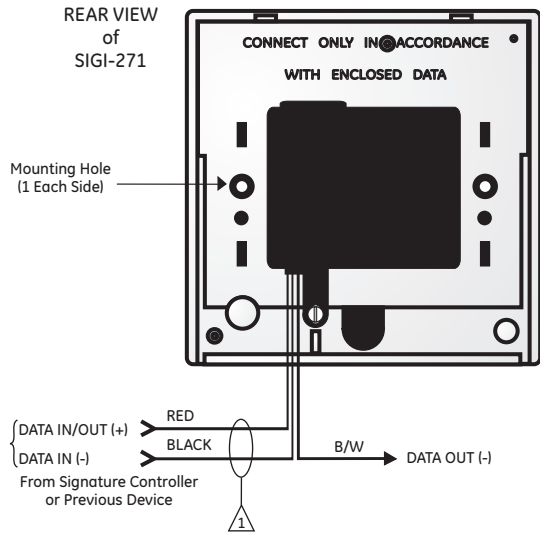

Specifications

Addressing Requirements	Uses 1 module address
Operating Current	Standby = 250 μ A Activated = 400 μ A
Type Code	Factory Set
Operating Voltage	15.2 to 19.95 Vdc (19 Vdc nominal)
Operating Temp.	32 °F to 120 °F (0 °C to 49 °C)
Storage Temp.	-4 °F to 140 °F (-20 °C to 60 °C)
Humidity	0 to 93% RH
LED Operation	On-board RED led: Flashes when in alarm; Glows steady when in alarm-stand-alone mode
Compatibility	Use with Signature Loop Controller
Call Point Material	Thermoplastic (red)
Agency Listings	CE Compliant

U.S.
T 888-378-2329
F 866-503-3996

Canada
T 519 376 2430
F 519 376 7258

Asia
T 852 2907 8108
F 852 2142 5063

Australia
T 61 3 9259 4700
F 61 3 9259 4799

Europe
T 32 2 725 11 20
F 32 2 721 86 13

Latin America
T 305 593 4301
F 305 593 4300

www.gesecurity.com

© 2006 General Electric Company
All Rights Reserved

Ordering Information

Model	Description	Carton	Ship Wt.
SIGI-271	Intelligent Call Point - English Markings	89 x 90 x 35mm	150g

Accessories

SR3T-P	Surface Mount Box - Red	89 x 90 x 35mm	50g
ETT/1-P	European Terminal Tray (for flush mounting)	89 x 90 x 35mm	47g
271-KG1	Replacement Glass Pack (5 inserts) - English only	82 x 48 x 14mm	70g
271-KG1-F005	Replacement Glass Pack (5 inserts) - Spanish only	82 x 48 x 14mm	70g
271-KG1-F1	Replacement Glass Pack (5 inserts) - Polish/English	82 x 48 x 14mm	70g
271-KG1-F2	Replacement Glass Pack (5 inserts) - Russian only	82 x 48 x 14mm	70g
271-KG1-F200	Replacement Glass Pack (5 inserts) - Hungarian/English	82 x 48 x 14mm	70g
271-KG1-F3	Replacement Glass Pack (5 inserts) - Arabic/English	82 x 48 x 14mm	70g



imagination at work